

## Model 60 Flake Ice Maker

Built for industrial use with high quality, heavy-duty parts, all North Star flake ice makers are constructed to be dependable and durable. The Model 60 ice maker is available in three stainless steel configurations – the **Elite, Plus and Standard** -- for use in all types of food processing, or carbon steel, used in non-food related industries such as concrete cooling. All of these configurations produce superior, sub-cooled flake ice for industrial applications.

<b>Feature</b>	<b>Benefit</b>
<i>North Star's lifetime evaporator warranty</i>	<ul style="list-style-type: none"> <li>• The best warranty in the business.</li> </ul>
<i>Makes sub-cooled flake ice</i>	<ul style="list-style-type: none"> <li>• Superior ice for most industrial applications -- the greatest surface area coverage for faster, more efficient cooling.</li> </ul>
<i>Stainless steel components incorporated in the design (varies depending on model)</i>	<ul style="list-style-type: none"> <li>• The smart choice for food safety and sanitation, will not corrode, low maintenance requirements.</li> </ul>
<i>Makes ice from fresh water or salt water</i>	<ul style="list-style-type: none"> <li>• Used worldwide in seafood processing, meat and poultry processing, concrete cooling and other industries</li> </ul>
<i>Solid stainless steel freezing surface -- Elite, Plus &amp; Standard models</i>	<ul style="list-style-type: none"> <li>• Long-lasting, durable and easy to clean. Will not chip, flake, pit or corrode like chrome-plated freezing surfaces.</li> </ul>
<i>Solid carbon steel freezing surface</i>	<ul style="list-style-type: none"> <li>• Also will not chip, flake or pit and corrosion-resistant while kept below freezing, or with minimal care.</li> </ul>
<i>Double-walled, stationary evaporator design</i>	<ul style="list-style-type: none"> <li>• No refrigerant seals to leak.</li> </ul>
<i>Constructed to ASME and PED codes</i>	<ul style="list-style-type: none"> <li>• Meets international safety requirements for pressure vessels.</li> </ul>
<i>Operates continuously with no defrost cycle</i>	<ul style="list-style-type: none"> <li>• All energy goes to making ice.</li> </ul>
<i>High R-Value polyurethane insulation and reinforced fiberglass exterior</i>	<ul style="list-style-type: none"> <li>• Energy efficient and durable.</li> </ul>
<i>North Star designed drip shield</i>	<ul style="list-style-type: none"> <li>• Complete separation of water and ice. No water is wasted.</li> </ul>
<i>Simple installation and operation</i>	<ul style="list-style-type: none"> <li>• Easy to use with minimal maintenance requirements.</li> </ul>



# Model 60 Flake Ice Maker

## Ice Maker Specifications

## High Capacity with a Small Footprint

**Refrigerant Control:** RFS (Refrigerant Float Switch) (Preferred) or Sporlan Levelmaster. Forced recirculation models also available

**Net Weight:** 7,000 lbs (3175 kg)  
**Volume:** 510 ft<sup>3</sup> (14.4 m<sup>3</sup>)  
**Drive Motor:** 1 HP  
**Pump Motor:** 1/2 HP  
**Suction Line:** 4" Sch 40  
**Liquid Line:** 1 1/2" Sch 80

**Oil Drain Line:** 1/2" MPT  
**Water Line:**  
**Tank Inlet:** 1/2" FPT  
**Tank Drain:** 1 1/4" FPT  
**Pump Outlet:** 1 1/4" FPT  
**Flow Control Valve Inlet:** 1 1/4" FPT

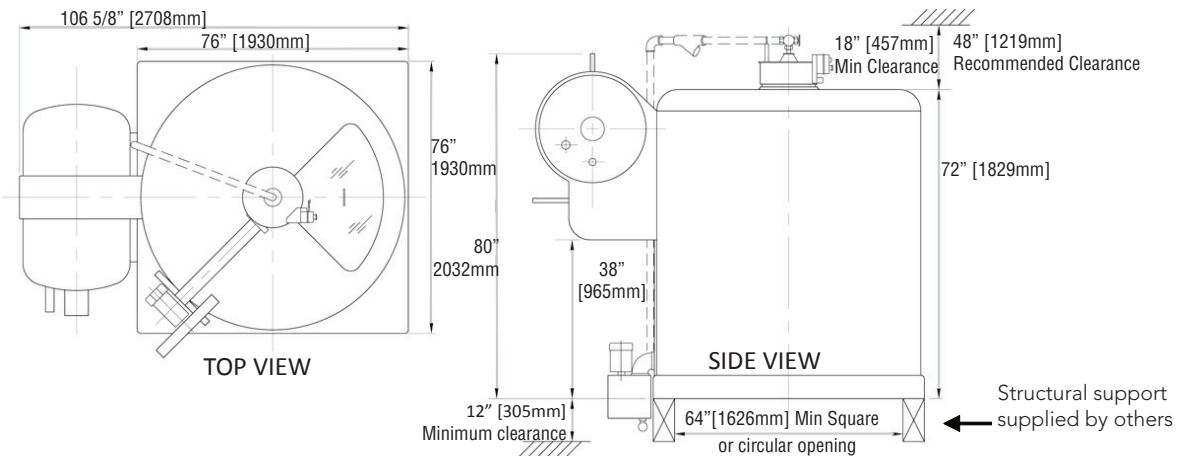

### Refrigerant Capacity at 70°F (21°C) Volume 8.68 Cubic Feet (.25 Cubic Meters)

### Refrigeration Requirement Tons of Refrigeration Per Ton of Ice

Refrigerant	Capacity (lbs/kg)	Water Temp. °F	Tons of Ref (UST)	Water Temp. °C	kW of Ref (MT)
Freon R-134a	710 lbs (322 kg)	40	1.20	5.0	4.67
Freon R-404a	685 lbs (311 kg)	50	1.25	10	4.84
Freon R-22	660 lbs (300 kg)	60	1.30	15.5	5.02
Ammonia R-717	330 lbs (150 kg)	70	1.40	21	5.44
		80	1.50	27	5.91

## Flake Ice Capacities in US Tons (Metric Tons)

Evap. Temp. - F - C	0 -18	-5 -21	-10 -23.5	-15 -26	-20 -29	-25 -32	-30 -34.5	-35 -37
<b>Stainless Steel Models</b>								
1.5mm Ice Thickness	16.2 (14.8)	18.8 (17.4)	21.4 (19.6)	24.1 (21.7)	26.7 (24.3)	28.9 (26.5)	30.8 (27.9)	31.6 (28.6)
2.0mm Ice Thickness	13.8 (12.7)	16.0 (14.9)	18.3 (16.8)	20.5 (18.5)	22.6 (20.6)	24.6 (22.6)	26.3 (23.9)	27.5 (24.8)
<b>Carbon Steel Models</b>								
1.5mm Ice Thickness	20.2 (18.6)	23.9 (22.2)	27.5 (25.1)	31.2 (28.2)	34.7 (31.6)	38.0 (34.7)	39.9 (36.2)	40.9 (37.0)
2.0mm Ice Thickness	17.5 (16.1)	20.6 (19.2)	23.9 (21.8)	27.1 (24.4)	30.2 (27.5)	32.6 (29.8)	34.1 (30.9)	35.0 (31.7)

Above capacities based on 60°F (15.5°C) make-up water and oil-free ammonia refrigerant. For different operating conditions including halocarbon refrigeration, please visit the North Star Website and use our Ice Maker Selector Tool at: [www.northstarice.com](http://www.northstarice.com).

### North Star Ice Equipment Corporation

8151 Occidental Avenue South  
P.O. Box 80227  
Seattle, WA 98108 USA  
Tel: 206-763-7300

Toll-free in USA: 1-800-321-1381  
Fax: 206-763-7323  
Email: [info@northstarice.com](mailto:info@northstarice.com)



[www.northstarice.com](http://www.northstarice.com)