

## Model 20 Flake Ice Maker

Built for industrial use with high quality, heavy-duty parts, all North Star flake ice makers are constructed to be dependable and durable. The Model 20 ice maker is available in three stainless steel configurations – the **Elite, Plus and Standard** -- for use in all types of food processing. Each of these configurations produce superior, sub-cooled flake ice for industrial applications.

<b>Feature</b>	<b>Benefit</b>
<i>North Star's lifetime evaporator warranty</i>	<ul style="list-style-type: none"> <li>• The best warranty in the business.</li> </ul>
<i>Makes sub-cooled flake ice</i>	<ul style="list-style-type: none"> <li>• Superior ice for most industrial applications -- the greatest surface area coverage for faster, more efficient cooling.</li> </ul>
<i>Stainless steel components incorporated in the design (varies depending on model)</i>	<ul style="list-style-type: none"> <li>• The smart choice for food safety and sanitation, will not corrode, low maintenance requirements.</li> </ul>
<i>Makes ice from fresh water or salt water</i>	<ul style="list-style-type: none"> <li>• Used worldwide in seafood processing, meat and poultry processing, concrete cooling and other industries</li> </ul>
<i>Solid stainless steel freezing surface -- Elite, Plus &amp; Standard models</i>	<ul style="list-style-type: none"> <li>• Long-lasting, durable and easy to clean. Will not chip, flake, pit or corrode like chrome-plated freezing surfaces.</li> </ul>
<i>Double-walled, stationary evaporator design</i>	<ul style="list-style-type: none"> <li>• No refrigerant seals to leak.</li> </ul>
<i>Constructed to ASME and PED codes</i>	<ul style="list-style-type: none"> <li>• Meets international safety requirements for pressure vessels.</li> </ul>
<i>Operates continuously with no defrost cycle</i>	<ul style="list-style-type: none"> <li>• All energy goes to making ice.</li> </ul>
<i>High R-Value polyurethane insulation and reinforced fiberglass exterior</i>	<ul style="list-style-type: none"> <li>• Energy efficient and durable.</li> </ul>
<i>North Star designed drip shield</i>	<ul style="list-style-type: none"> <li>• Complete separation of water and ice. No water is wasted.</li> </ul>
<i>Simple installation and operation</i>	<ul style="list-style-type: none"> <li>• Easy to use with minimal maintenance requirements.</li> </ul>

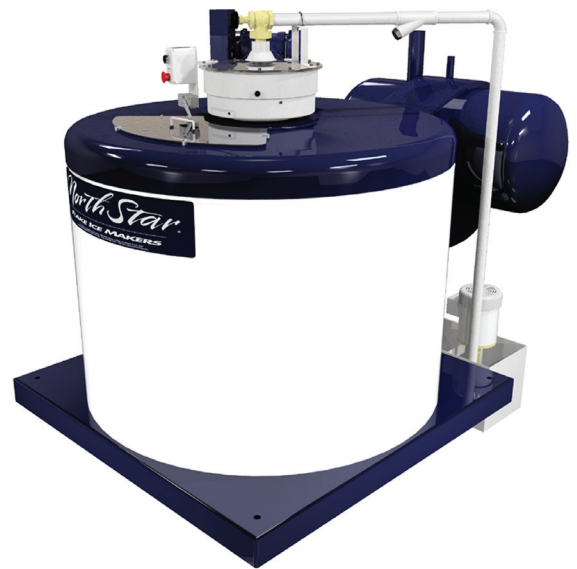

# Model 20 Flake Ice Maker

## Ice Maker Specifications

## High Capacity with a Small Footprint

**Refrigerant Control:** RFS (Refrigerant Float Switch) (Preferred) or Sporlan Levelmaster. Forced recirculation models also available

**Net Weight:** 3,000 lbs (1361 kg)  
**Volume:** 240 ft<sup>3</sup> (7.79 m<sup>3</sup>)  
**Drive Motor:** 1/2 HP  
**Pump Motor:** 1/2 HP  
**Suction Line:** 2 1/2" Sch 40  
**Liquid Line:** 1 1/4" Sch 40

**Oil Drain Line:** 1/2" MPT  
**Water Line:**  
**Tank Inlet** 1/2" FPT  
**Tank Drain** 1 1/4" FPT  
**Pump Outlet** 1 1/4" FPT  
**Flow Control Valve Inlet** 1 1/4" FPT

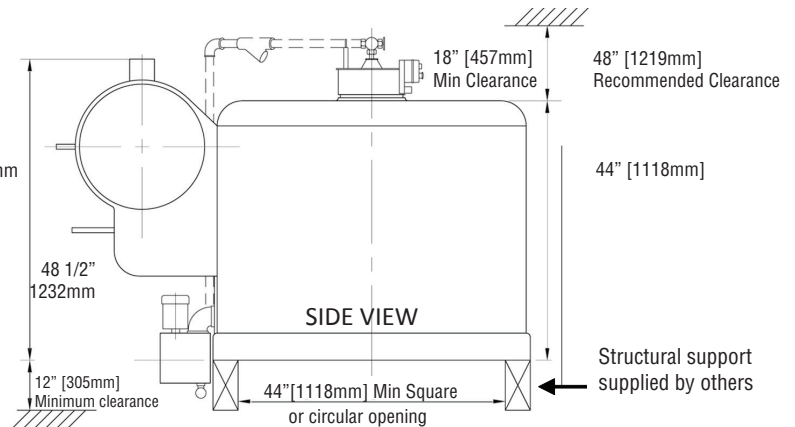
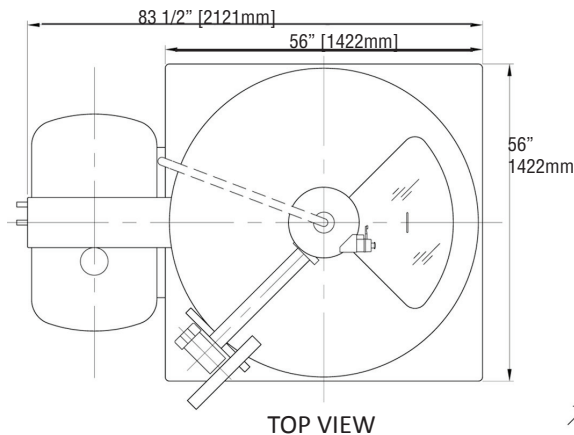

### Refrigerant Capacity at 70°F (21°C) Volume 8.68 Cubic Feet (.25 Cubic Meters)

### Refrigeration Requirement Tons of Refrigeration Per Ton of Ice

Freon R-134a	175 lbs (79 kg)	Freon R-404a	166 lbs (75 kg)	Water Temp. °F	40	50	60	70	80
				Tons of Ref (UST)	1.20	1.25	1.30	1.40	1.50
Freon R-22	159 lbs (72 kg)	Ammonia R-717	80 lbs (36 kg)	Water Temp. °C	5.0	10	15.5	21	27
				kW of Ref (MT)	4.67	4.84	5.02	5.44	5.91

## Flake Ice Capacities in US Tons (Metric Tons)

Evap. Temp. - F - C	0 -18	-5 -21	-10 -23.5	-15 -26	-20 -29	-25 -32	-30 -34.5	-35 -37
<b>Stainless Steel Models</b>								
1.5mm Ice Thickness	7.2 (6.8)	8.3 (7.9)	9.4 (8.7)	10.3 (9.4)	11.0 (10.0)	11.5 (10.4)	11.5 (10.4)	11.7 (10.6)
2.0mm Ice Thickness	6.0 (5.5)	7.0 (6.4)	7.8 (7.1)	8.6 (7.8)	9.2 (8.4)	9.5 ( 8.6)	9.6 ( 8.6)	9.7 ( 8.8)

Above capacities based on 60°F (15.5°C) make-up water and oil-free ammonia refrigerant. For different operating conditions including halocarbon refrigeration, please visit the North Star Website and use our Ice Maker Selector Tool at:

[www.northstarice.com](http://www.northstarice.com)

### North Star Ice Equipment Corporation

8151 Occidental Avenue South  
 P.O. Box 80227  
 Seattle, WA 98108 USA  
 Tel: 206-763-7300

Toll-free in USA: 1-800-321-1381  
 Fax: 206-763-7323  
 Email: [info@northstarice.com](mailto:info@northstarice.com)

*North Star*

[www.northstarice.com](http://www.northstarice.com)